

Ex II 3 G, Ex ec IIA T4 Gc
T_{amb} -30°C to +60°C
US/UL/ExTR15.0133/01
 Do not open when energised

Atex Label

Connection Diagram	
Speed Control 500 rpm	Speed Control 1100 rpm
DOR : CCW-DE	DOR : CCW-DE
BROWN — PHASE	BROWN — PHASE
BLUE — NEUTRAL	BLUE — NEUTRAL
BLACK — NEUTRAL or N/C	BLACK — PHASE

Connection Diagram Label

Wellington
ECF2-8AXM51
 INPUT: 100-240Vac, 50-60Hz, 0.19-0.10A
 OUTPUT : 13W@1800rpm
 EP -30° to +50°C, DOR : CCW-DE
 Dual Speed 500 / 1100rpm

Product Label

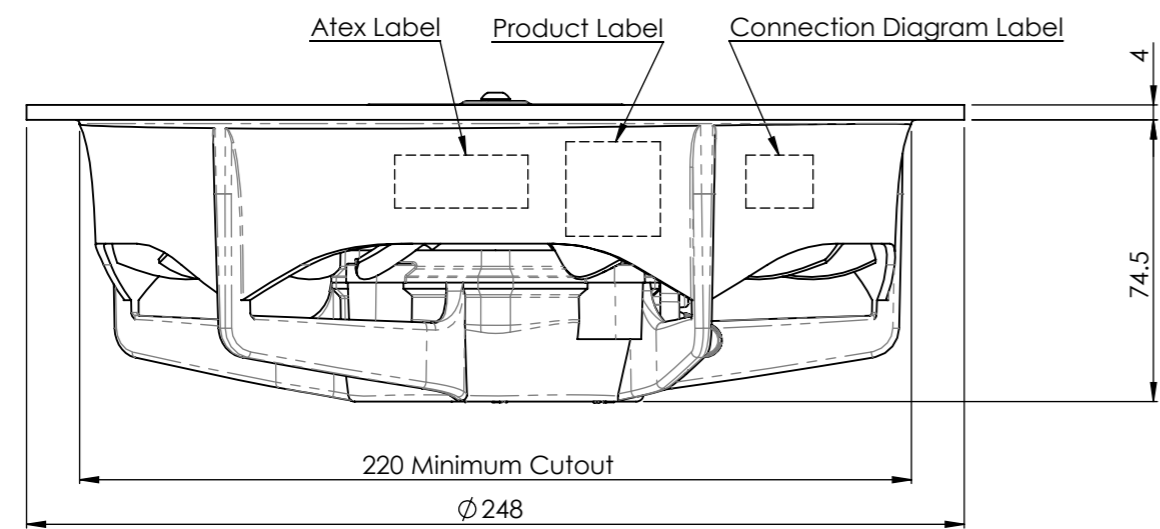

MOTOR RATING

PRODUCT CODE	Max Output Watts @ Corresponding rpm	Supply voltage, Frequency	DOR, Mode of Operation
ECF2-8AXM51	13 Watts @ 1800 rpm	100-240Vac, 50-60Hz	CCW-DE Continuous, Speed Control 500/1100 rpm

NOTES:
 1. Refer operation instructions for installation details.

B-4	2	WCP4082	Conical washer added	23/09/2021	BPi	ASo
n/a	1	n/a	Initial release	17/03/2021	BPi	ASo
ZONE	ISSUE	ECN	BRIEF NOTE	DATE	DRAWN	CHKD

DO NOT SCALE OFF DRAWING

The information contained in this drawing is confidential. Reproduction of this document in any form is subject to explicit written permission. © COPYRIGHT 2004 - 2009 Wellington Drive Technologies Ltd

Description: **Fan Pack Assembly**

Product Code: Refer to table above

Orthographic Projection

Third Angle

LIFECYCLE STATE: **Production Released**

Scale: NTS

Dimension Units: mm

Sheet size: A3

Sheet: 1 of 1

DWG No.: ECF2-8AXM51